

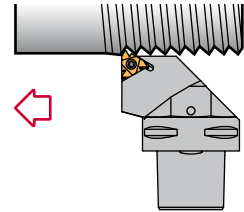

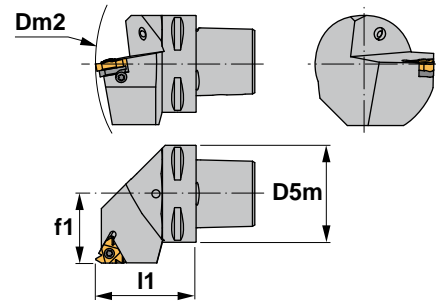

Characteristics:
Multipurpose threading toolholder
for negative lay down inserts.
PSC with internal coolant.

Eigenschaften:
Multifunktions-Klemmhalter zum
Gewindedrehen für negative
Wendeschneidplatten.
PSC mit Innenkühlung.



SE 90°

Reference Bezeichnung	D5m	Dm2 min.	f1	l1	Insert size Wendeschneidplatte	
PSC32-SER/L22040-16	32	124	22	40	16 ER/L..	0,210
PSC40-SER/L27050-16	40	140	27	50	16 ER/L..	0,420
PSC50-SER/L35060-16	50	165	35	60	16 ER/L..	0,800
PSC63-SER/L45065-16	63	190	45	65	16 ER/L..	1,100
PSC32-SER/L22040-22	32	124	22	40	22 ER/L..	0,210
PSC40-SER/L27050-22	40	140	27	50	22 ER/L..	0,420
PSC50-SER/L35060-22	50	165	35	60	22 ER/L..	0,800
PSC63-SER/L45065-22	63	190	45	65	22 ER/L..	1,100
PSC80-SER/L55080-22	80	250	55	80	22 ER/L..	2,740

WARNING!! Because of large thread profile, modification may have to be made to the toolholder to achieve full depth of thread.
ACHTUNG!! Bei großen Gewindeprofilen könnte eine Änderung im Klemmhalter erforderlich sein, um die volle Gewindetiefe zu erreichen.

Reference Bezeichnung			 R	 L		Nm
PSC32-SER/L22040-16	SA3	5510	YE3	YI3	SY3	2.0
PSC40-SER/L27050-16	SA3	5510	YE3	YI3	SY3	2.0
PSC50-SER/L35060-16	SA3	5510	YE3	YI3	SY3	2.0
PSC63-SER/L45065-16	SA3	5510	YE3	YI3	SY3	2.0
PSC32-SER/L22040-22	SA4	5520	YE4	YI4	SY4	4.0
PSC40-SER/L27050-22	SA4	5520	YE4	YI4	SY4	4.0
PSC50-SER/L35060-22	SA4	5520	YE4	YI4	SY4	4.0
PSC63-SER/L45065-22	SA4	5520	YE4	YI4	SY4	4.0
PSC80-SER/L55080-22	SA4	5520	YE4	YI4	SY4	4.0

E R/L

Triangular negative inserts for external threading.  C03,05,08,10
Dreikantige negative Wendeschneidplatten zum Außengewindedrehen.

Reference / Bez.	l	d
16 ER/L..	16,00	9,52
22 ER/L..	22,00	12,70

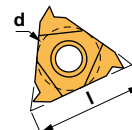

E R/L

E R/L TD



ER/L-LG

